

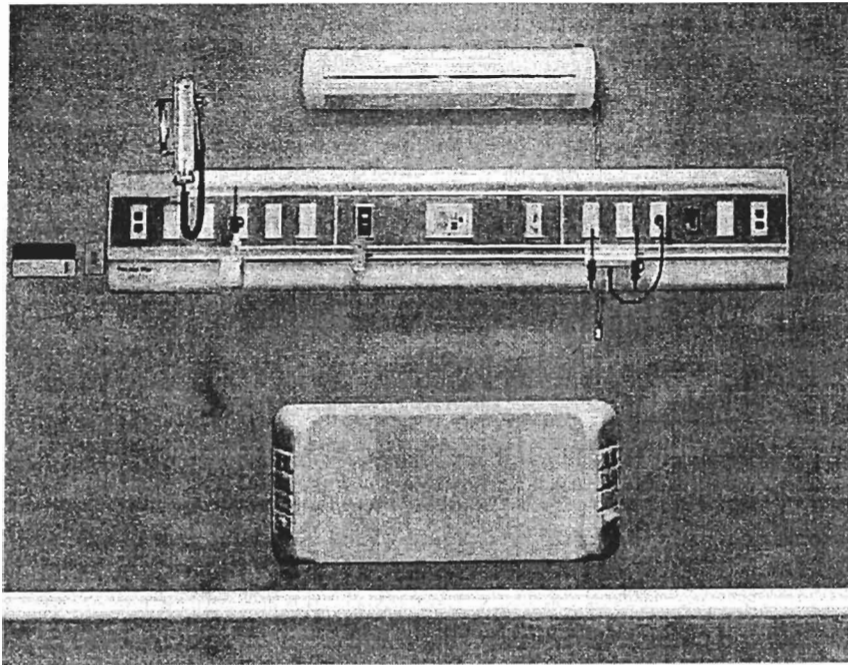

PROVIDER PLUS™

Installation Manual

PROVIDER PLUS™



OVERVIEW

The Provider Plus™ is a UL-listed, surface-mounted, horizontal modular headwall assembly. This system uses one or more horizontal component channels to locate services such as medical gas, electrical and communications. The vertical service chase, if required, provides for the concealment of incoming electrical and medical gas piping (supplied by others). The chase includes a decorative removable access panel to conceal incoming services, and is equipped with two integral vertical equipment mounting tracks.

Horizontal channels are an integral part of the horizontal rail assembly and are flush with the front face of the unit. The lower channel surface is flat and smooth to facilitate ease of cleaning. The Provider Plus consists of two types of units: the Provider Plus PC and the Provider Plus AC. The Provider Plus PC has channels that are powder coated in a “Surf” color, and are removable to allow replacement as necessary. The Provider Plus AC has clear anodized aluminum channels that are non-removable.

Horizontal channel accessories are available in a sufficient variety to meet the needs of typical hospital applications. One of the available accessories is a horizontal channel bracket that automatically locks in place. This bracket includes a plastic locking pad to protect the surface finish of the channel and is designed for one-hand operation. All accessories are as called for on the project drawings.

The Provider Plus unit may be installed along with an optional Bed Docker™. If so, please refer to the Bed Docker instructions for that portion of the installation.

UNPACKING AND INSPECTION

1. Upon receipt of Provider Plus units and prior to unpacking, inspect shipping containers for damage. Document any damage found and notify the carrier and Modular Services Company.
2. Clear a large work area near the location where the unit is to be installed.
3. Locate the carton for the unit you wish to install. Labels at each end of the carton identify the unit type and general description of contents, as well as the room number or area of installation (if applicable).
4. Unpack and inspect units for defects in materials or workmanship prior to installation. It is the responsibility of the customer to report any damage or deficiencies to Modular Services immediately upon discovery.

PREPARATION

1. Review the final approved shop drawings and the submittal booklet, which will provide you with technical details specific to your installation, such as:
 - Wiring diagrams
 - Equipment types and quantities
 - Shop drawings of each type unit
 - Room numbers and locations in building (if applicable)
2. **WARNING:** Before installation of Provider Plus units, make sure walls are constructed of at least 20-gauge steel studs. Failure to do so could lead to the collapse of the unit, with resulting personal injury or property damage.
3. Illustrations in this manual show typical installation for a one-tier Provider Plus unit. Multi-tier units are installed in a similar manner, with rough-in template locations adjusted to match the unit type (Figure 1). Required templates and specific template locations are detailed in the approved shop drawings and submittal booklet, along with requirements for overbed lights and Bed Docker modules.

NOTE: When an overbed light is required above the Provider Plus unit, the rough-in box (provided by others) should be positioned as required for the particular type of fixture being used.

Figure 1.

One-Tier Unit

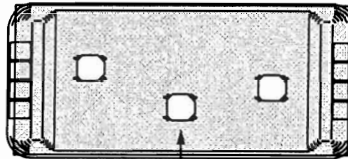
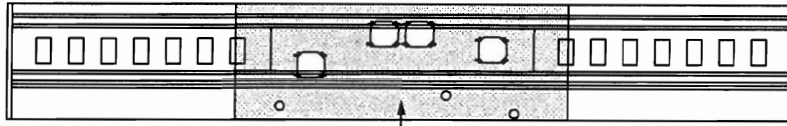
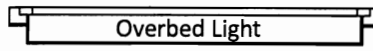

Two-Tier Unit

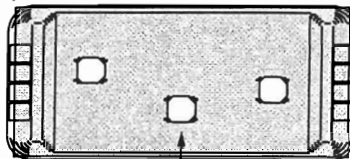
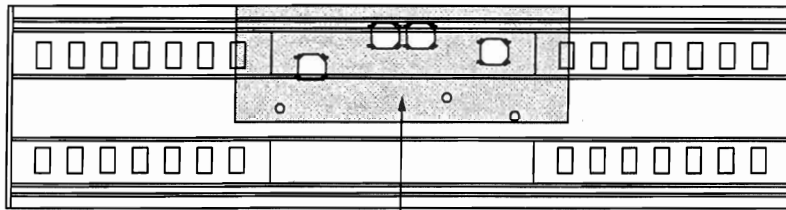
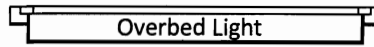

Three-Tier Unit

Provider Plus (electric only)
Template Location

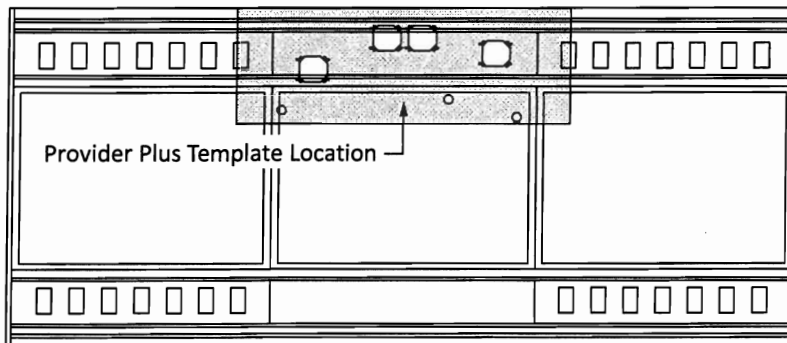

After installation of medical gas pipes to the locations indicated on the template and pressure testing, stubs must be cut to the lengths shown in Figure 3 in order to accommodate connection to the Provider Plus unit. Required wall finishes may be applied at this time, prior to installation of the unit.

IMPORTANT: Wainscoting should not be installed behind the Provider Plus unit. Ideally, partial wall coverings should be applied after the unit is installed. If the coverings are to be applied before installation of the Provider Plus unit, a section equal to the width of the unit should remain uncovered.

UNIT INSTALLATION

Remove top and bottom covers (Figure 4). To remove covers, unscrew #6 flathead screws at top and bottom and rotate covers out and away from body of unit. Do not mix covers with those of other units, as lengths may vary.

Figure 3.

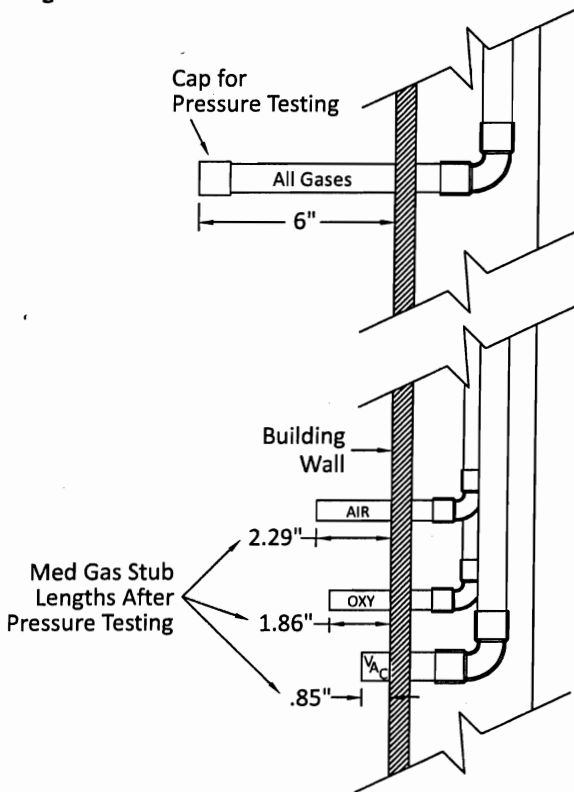
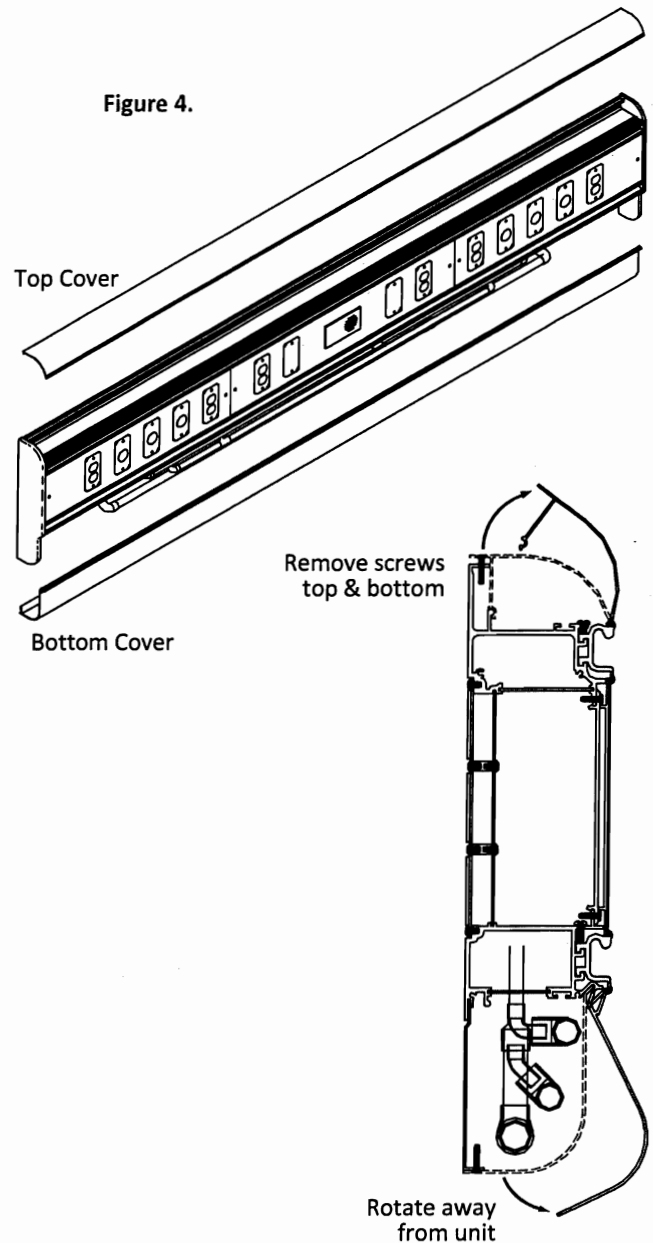

Figure 4.



To attach hanging brackets, measure 9.8" below the device console centerline to locate bottom of hanger brackets. Mark a level horizontal line at this location for use in aligning the brackets. Mount two hanger brackets (Figure 5, item 1) with 3/8" Rawl hollow wall anchors (item 2) or equivalent (by others) into wall studs only. Position hanger brackets so that both are within the length of the unit and will engage two studs each. Drill 25/64" holes through drywall and metal studs. Fasten with anchors after leveling hangers and tighten fully.

NOTE: For seismic installations, see seismic addendum for mounting and fastening instructions.

Position unit over hanger brackets and lower into place (Figure 6). Take precautions not to damage medical gas stubs in wall. Stubs may need to be temporarily pushed back into the wall 1/2" to 3/4" to clear med gas manifold assembly while lowering unit into place. Align the unit so that each med gas service stub engages its respective tee (provided by others) on the med gas manifold. After all stubs are engaged, remove center front fascia cover to check alignment of junction boxes with service entry points on back of unit. Make adjustments to ensure all services (med gas and electrical) are aligned.

Once unit is aligned with all services, locate position of all wall studs behind the unit. Using a 25/64" drill bit, drill one hole per stud through detent in top extrusion (Figure 7). Each anchor must pass through unit, drywall and wall stud. Fasten with 3/8" Rawl hollow wall anchors or equivalent (by others). Level unit and fully tighten all anchors.

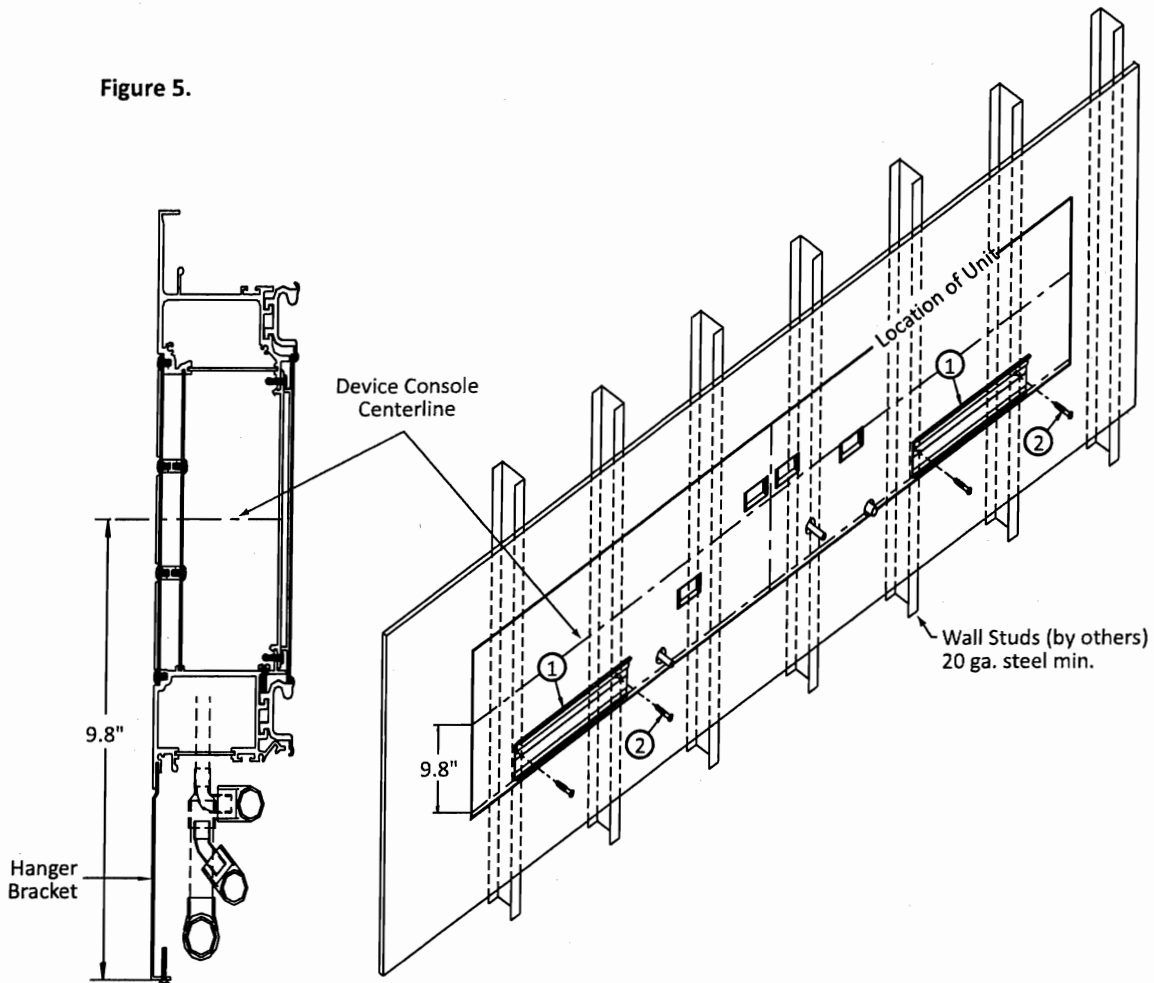

Figure 6.

NOTE: For seismic installations, see seismic addendum for mounting and fastening instructions.

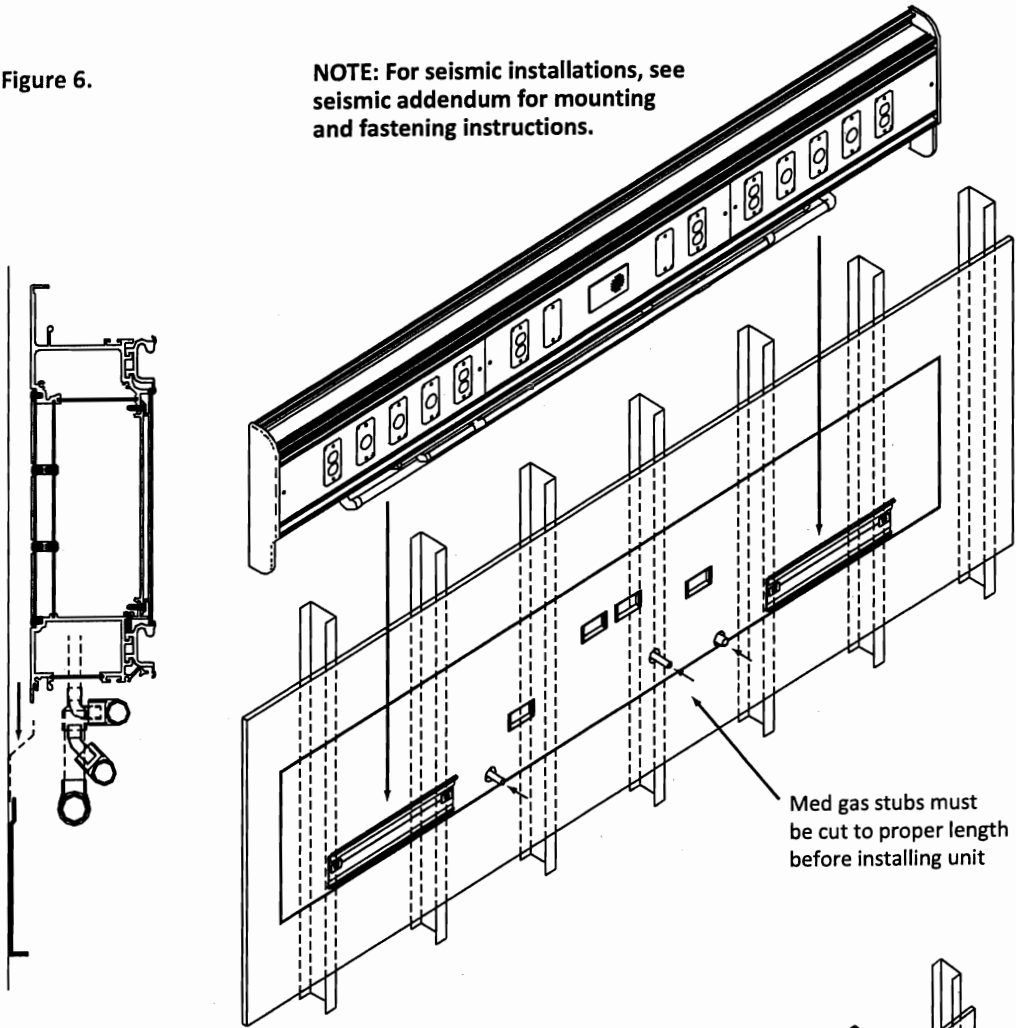
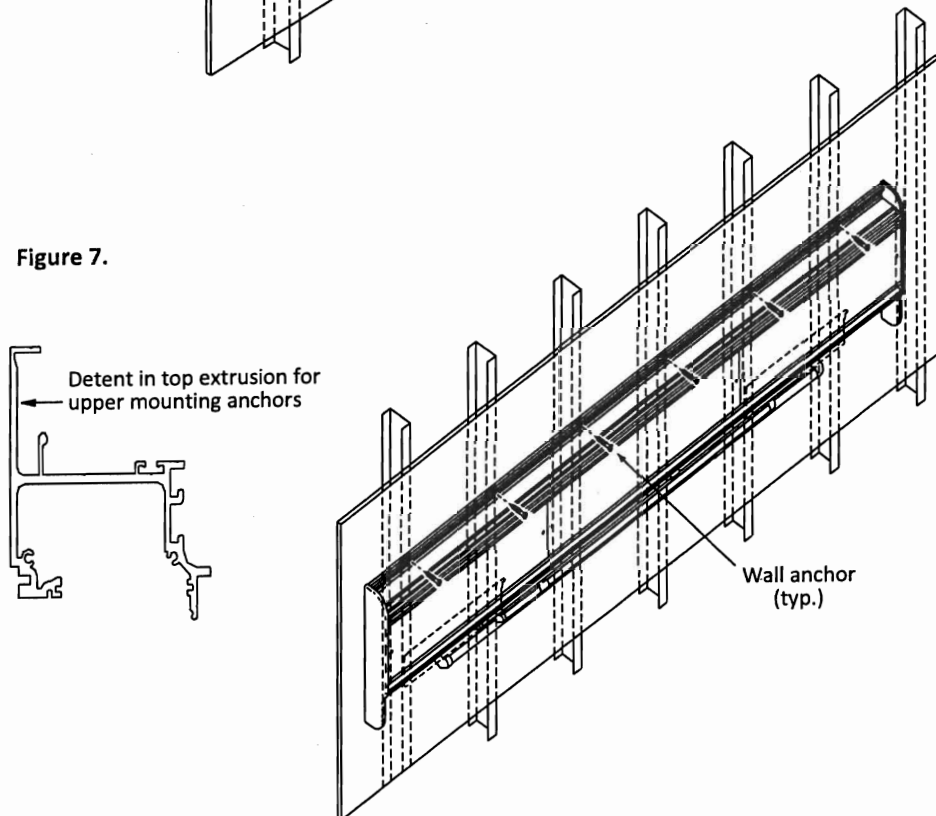

Figure 7.



MEDICAL GAS CONNECTIONS

Use extreme care in making the medical gas service connections. Each single-point service connection has been provided with a color-coded medical gas label. All medical gas connections are to be made to manifold assembly according to applicable federal, state and local codes.

ELECTRICAL CONNECTIONS

Remove center front fascia cover to expose all electrical service entry points. Install grommeted cover plate provided (Figure 8) on each junction box. Make all electrical connections for each service. Replace front fascia cover with trim strips (not reversible) on each end.

NOTE: All electrical connections are to be made according to applicable federal, state and local codes.

LOW-VOLTAGE CONNECTIONS

Provisions have been made for the installation of such items as nurse call, code blue, telephone outlets, television outlets, heart monitor outputs, etc., according to the project drawings. A blank plate is typically provided for these areas that may be replaced or removed and punched as required to accommodate the various devices.

NOTE: Conduit from the low-voltage service termination point in the optional Bed Docker unit to the nurse call location (when required) must be provided and installed by others during installation.

CARE AND MAINTENANCE

1. Clean with mild detergent and warm water. **Do not use lubricants or oils on unit.**
2. Avoid excessive moisture build-up, as it can damage mechanisms in the unit.
3. Disinfect as required with disinfectant approved by the Environmental Protection Agency.
4. To remove difficult spots or stains, use standard household cleansers and a soft-bristled brush.
5. For parts or repairs, contact your sales representative.

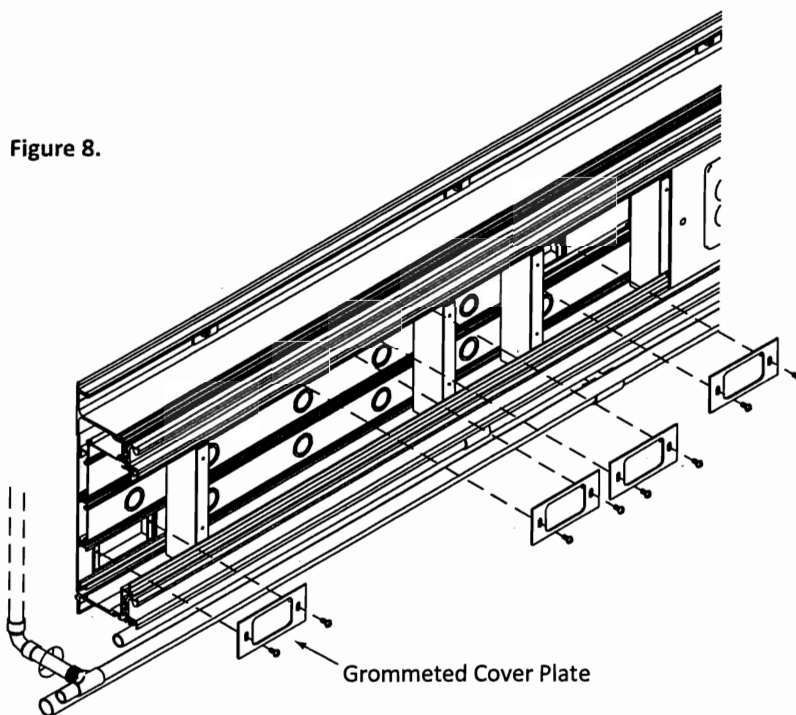

INSTALLATION TERMS AND CONDITIONS

Each Modular Services unit, or unit section, shall be completely pre-wired for normal, emergency and low voltage according to the approved submittal. Communication devices and wiring shall be supplied by others. These devices include nurse call, television, code blue, telephone, monitor jacks, etc.

The customer shall be responsible for all electrical conduits (above the junction boxes), wiring hook-up of electrical services, and if applicable, interconnect wiring between sections. All hardware light fixtures shall be installed, wired and lamped by contractor. After installation is complete, the customer shall test equipment functions, as well as electrical receptacles and ground, in accordance with the National Electrical Code.

Medical gas contractor shall be responsible for piping and hook-up of all medical gas services. The medical gas contractor shall be responsible for purging, pressure testing, gas identification, and system certification in accordance with NFPA 99.

Modular Services Company shall have no responsibility or liability for delays, however caused. Owner shall hold Modular Services harmless from damages or injury related to any failure or neglect of owner, its employees, agents or licensees. Modular Services shall not be liable for consequential damages; makes no warranties, expressed or implied; and assumes no obligation other than those expressly contained herein.

WARRANTY

Modular Services Company warrants that all equipment assemblies shall be free from defects in material and workmanship for a period of 12 months from date of the owner's acceptance to the installing contractor or the date the equipment is put into service, whichever comes first. Warranty excludes electric lamps and/or any material not furnished by Modular Services. Warranty does not cover damage due to improper installation and/or abuse.

It is the responsibility of the customer to report any noted product deficiencies to Modular Services immediately upon discovery. It is the responsibility of Modular Services to expediently resolve the discrepancy. Any modification made to the product without the written authorization from Modular Services will void this warranty.

Also, in the event product modifications or repairs are made without the written consent of Modular Services, Modular Services shall not be held liable for any cost associated with the modification or repair.

There are no warranties of fitness which extend beyond the description on the face hereof.



109 NE 38th St. • Oklahoma City, OK 73105
Tel: 800.687.0938 • Fax: 405.528.0368
www.headwalls.com • info@headwalls.com