

# **AirStar**<sup>®</sup> **DENTAL AIR SYSTEM**

## **Installation and Operation Manual**



**AIR  
TECHNIQUES**  
INC.

**ISO**  
9001  
ISO 13485  
FDA-GMP COMPLIANT



## **TABLE OF CONTENTS**

---

<b>SECTION</b>	<b>PAGE</b>
Safety Instructions . . . . .	4
Congratulations . . . . .	5
Warranty . . . . .	5
On-Line Warranty Registration . . . . .	5
Key Parts Identification . . . . .	6
Sizing Guide . . . . .	7
Operating Information . . . . .	7
Site Requirements . . . . .	8
Installation Information . . . . .	10
Troubleshooting . . . . .	12
Product Specifications . . . . .	14
Replacement Parts . . . . .	14
Maintenance . . . . .	15
Optional Accessories . . . . .	15

## **LIST OF ILLUSTRATIONS**

---

<b>FIGURE</b>	<b>TITLE</b>	<b>PAGE</b>
1	AirStar Parts Location . . . . .	6
2	Overall Site Requirements . . . . .	9
3	Electrical Connection Box . . . . .	10
4	Intake Filter Location . . . . .	15
5	Moisture Monitor Location . . . . .	15
6	5 Micron Filter Location . . . . .	15

# SAFETY INSTRUCTIONS

---

Use of the **AIRSTAR** not in conformance with the instructions specified in this manual may result in permanent failure of the unit.

**WARNING:** To prevent fire or electrical shock, do not expose this appliance to rain in or moisture.

All user serviceable items are described in the maintenance section.

Manufacturing date code on serial number label is in the format Month YYYY.

## ATTENTION USERS:



Alerts users to important Operating and Maintenance instructions. Read carefully to avoid any problems.



Warns users that uninsulated voltage within the unit may be of sufficient magnitude to cause electric shock.

**I ON**  
**O OFF**

Indicates the ON and OFF position for the Equipment power switch.



MEDICAL ELECTRICAL EQUIPMENT

WITH RESPECT TO ELECTRICAL SHOCK, FIRE, MECHANICAL AND OTHER SPECIFIED HAZARDS ONLY  
IN ACCORDANCE WITH UL-60601-1, CAN/CSA C22.2 NO.601.1  
66CA



Indicates protective Earth Ground for the Equipment power switch.

All AirStar compressors comply with NFPA 99C level 3 requirements

---

## **CONGRATULATIONS**

Your AIRSTAR generates 100% oil-less, ultra-dry dental air which protects valuable handpieces from premature failure due to the effects of moist air and the build-up of oil residue. Because no oil is used for mechanical lubrication, there is no chance of introducing an oily film to a prepared surface which could compromise resin retention and restorations, wasting chair time. Most important, your patients's health is protected with ultra-dry air that provides an environment that is not conducive to bacterial growth.

The AIRSTAR utilizes a long stroke, small bore piston to compress the air. This piston is bonded with an anti-friction polymer to eliminate the need for oil. The air is forced through the Membrane Dryer System consisting of the cooler and the membrane. This system removes moisture and air impurities providing the driest possible compressed air while maximizing performance. This 100% ultra-dry air is reserved in the main storage tank for use by the operatory air system. The AIRSTAR features include:

- Virtually Maintenance Free
- Low Pressure Dew Point
- Maximum Dryness with Quadruple Filtered Air
- Uninterrupted Compressor Availability
- Compact size for space-saving installation

Since 1971, when Air Techniques pioneered the manufacture of oil-less air for dentistry, thousands of dentists have depended on their AIRSTAR. Now that your practice has an AIRSTAR , you, too, can depend on the delivery of 100% oil-less, ultra-dry air and efficient, trouble-free operation.

---

## **WARRANTY**

Each AIRSTAR is warranted to be free from defects in material and workmanship from the date of installation for a period as follows:

- Standard Warranty: 2 years (24 months) on complete unit.
- Extended Warranty: 3 years (36 months) all motors, heads and pistons.
- Total 5-year Warranty on all motors, heads and pistons.

Any item returned to our factory through an authorized distributor, will be repaired or replaced at our option at no charge provided that our inspection shall indicate it to have been defective. Dealer labor, shipping and handling charges are not covered by this warranty.

This warranty does not apply to damage due to shipping, misuse, careless handling or repairs by other than authorized service personnel. Warranty is void if equipment is installed or serviced by other than dealer service personnel authorized by Air Techniques. Air Techniques, Inc. is not liable for indirect or consequential damages or loss of any nature in connection with this equipment.

This warranty is in lieu of all other warranties expressed or implied. No representative or person is authorized to assume for us any liability in connection with the sale of our equipment.

---

## **ON-LINE WARRANTY REGISTRATION**

Quickly and easily register your new AIRSTAR on-line. Just have your product model and serial numbers available. Then go to the Air Techniques web site, [www.airtechniques.com](http://www.airtechniques.com), click the Warranty Registration link at the top of the page and complete the registration form. This on-line registration ensures a record for the warranty period and helps us keep you informed of product updates and other valuable information.

# KEY PARTS IDENTIFICATION

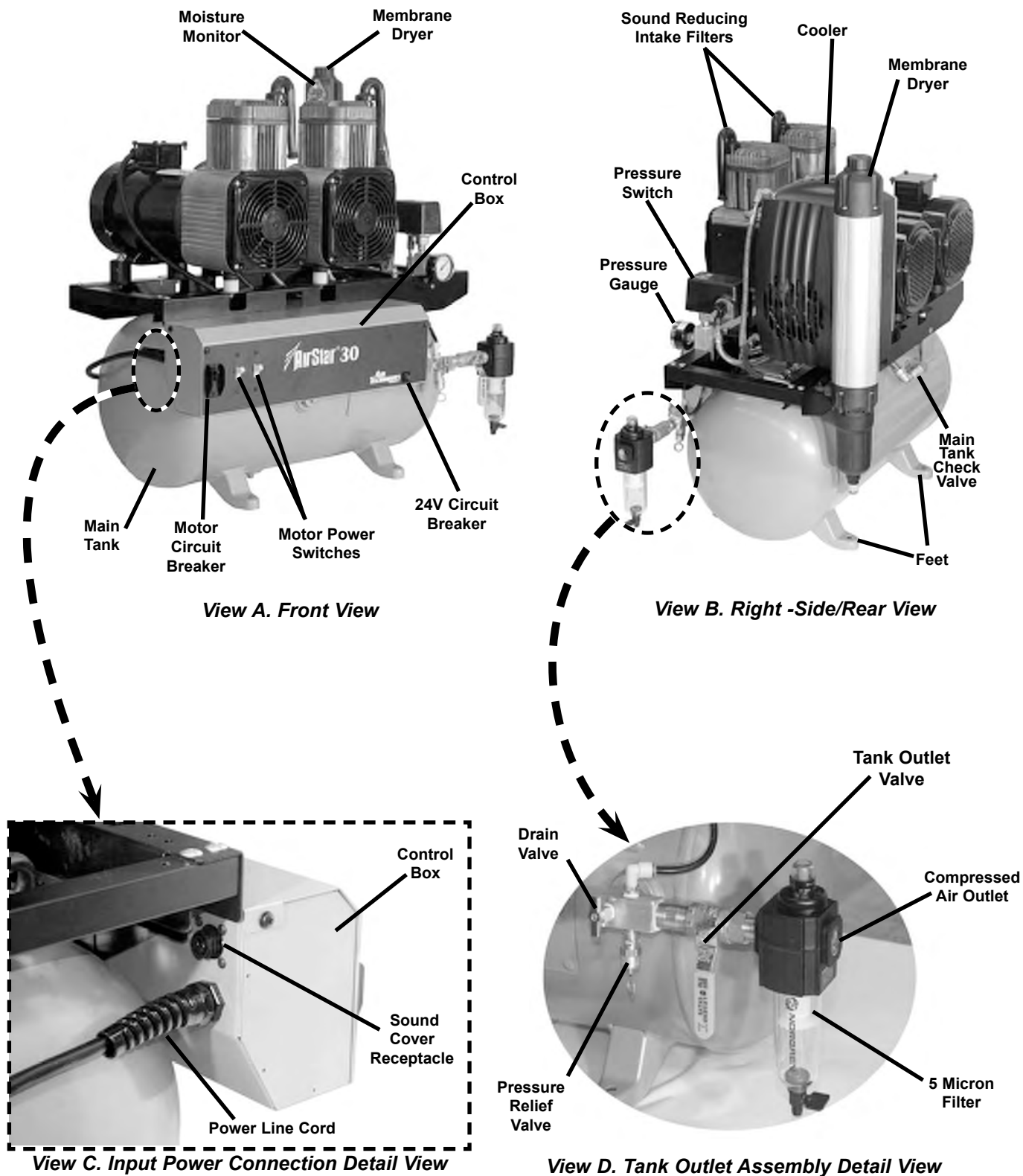

**Figure 1. AirStar Parts Location**

Choosing the correct size AIRSTAR for your practice depends on the number of air users and the anticipated air demand. To assure optimum compressor operation, the air demands should not exceed the number of air handpiece users shown in the chart below:

Model	Recommended Number of Users	Number of Heads
AS21	2 - 3	1
AS22	2 - 3	1
AS30	3 - 4	2
AS50	5 - 7	2

---

## OPERATING INFORMATION

### ■ AS21 and AS22

- If a remote Control Panel is being used, the circuit breaker on the face of the compressor Control box must be in the ON position.
- The 24 volt circuit breaker must also be in the ON position. Make sure the reset button is flush with the face of the circuit breaker. If it isn't, push it in to reset.
- If a Remote Control Panel is not being used, be sure that the yellow and the orange wires are connected to one another. These wires are located in the pressure switch. The circuit breaker located on the face of the compressor Control Box is the power control for the motor.

### ■ AS30 and AS50

- If a Remote Control Panel is being used, BOTH switches on the face of the compressor Control Box must be in the ON position.
- If a Remote Control Panel is not being used, be sure that the yellow and the orange wires are connected to one another. These wires are located on the pressure switch. The power switches located on the face of the compressor Control Box are the power control for each motor.

**Note:** Compressor motors are designed to run together. Do not run one head at a time unless one head has failed and you are waiting for service.

- The motor circuit breaker must be kept in the ON position and should not be used as a switch.

# SITE REQUIREMENTS

---

Requirement \ AirStar Model	AIRSTAR 21	AIRSTAR 22	AIRSTAR 30	AIRSTAR 50
Voltage Min/Max * (VAC)	105/125	200/250	200/250	200/250
Frequency (Hz)	60	60	60	60
Full Load Amps	15.0	8.0	8.0	16.0
Minimum Circuit Breaker Rating (Amps)	30	20	20	30
Minimum. Wire Size (AWG)	10	12	12	10

\* Install a buck or boost transformer if service is above or below these ratings

- Service Clearance: Allow 12" on all sides for all models.
- Ambient Temperature: Must not exceed 105°F
- Air System Plumbing Connection: 1/2" F.N.P.T. Shut-off valve and a 4 ft. pressure hose (supplied)  
 Air distribution piping for all models - 1/2", type "L" or type "K" copper  
 If pipe volume is too great, more than 235 in<sup>3</sup> or more than 100 ft. of 1/2" diameter pipe, a pressure regulator should be installed between the main tank and the distribution piping and pressure set at 80 PSI.
- Environmental:  
 Operating Indoor use at altitudes up to 2000m. Temperature 5 to 40°C (41 to 105°F).  
 Maximum relative humidity 80% for temperatures up to 31°C, decreasing linearly to 50% relative humidity at 40°C.  
 Supply voltage fluctuation of +/- 10% of nominal voltage.
- Classification:  
 IEC 60601-1  
 Protection against electric shock (5.1, 5.2). Class I  
 Applied Parts: There are no Applied Parts.  
 Protection against harmful ingress of water (5.3). Ordinary, IPX0  
 Degree of safety in the presence of flammable anesthetics mixture with air or with oxygen or with nitrous oxide (5.5). Not suitable.  
 Mode of operation (5.6). Continuous

# SITE REQUIREMENTS

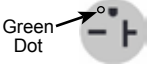
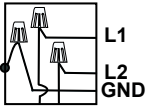
Type		Style
AS10	5-20R NEMA*	Green Dot 
AS21		
AS22	6-20R NEMA*	Green Dot 
AS30		
AS50	Hard Wired**	 L1
AS70		L2 GND

\*Hospital Grade Receptacle  
 \*\*Disconnect Needed for Service

## Connection to 24 V Switch Only

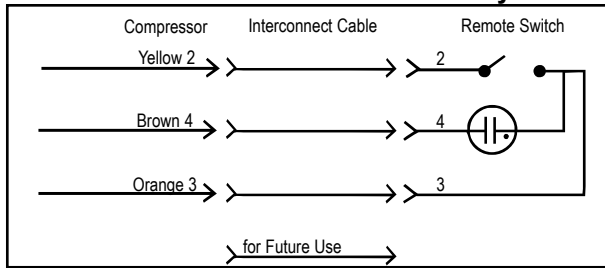

Use 18 Gauge, 4 Conductor, Interconnect Cable Between Compressor and Remote Switch

## Connection without 24 V Switch

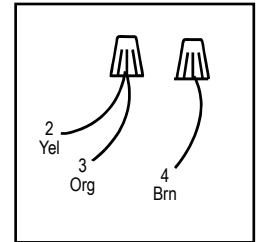

Electrical Box Connections

## OUTSIDE AIR PIPE

2-Inch Pipe for Air Intake.  
 Must be protected from rain and animals

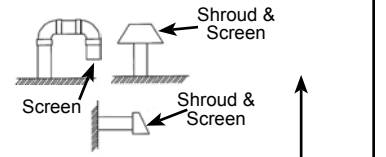

Kit includes 70" of clear PVC  
 Tubing per Number of Cylinders

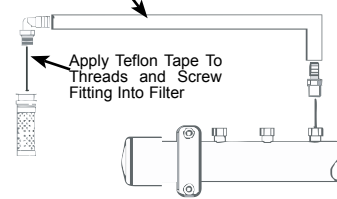

Air Intake Manifold Detail

Remote Air Intake  
 Kit Manifold  
 (see detail)

13" max  
 Drip Leg

2" Pipe & flexible hose for  
 Air Intake supplied with  
 Remote Air Intake Kit Manifold

36" max  
 12" min  
 24" max  
 1/2" MNPT End fitting  
 1/2" Copper Main Air Line

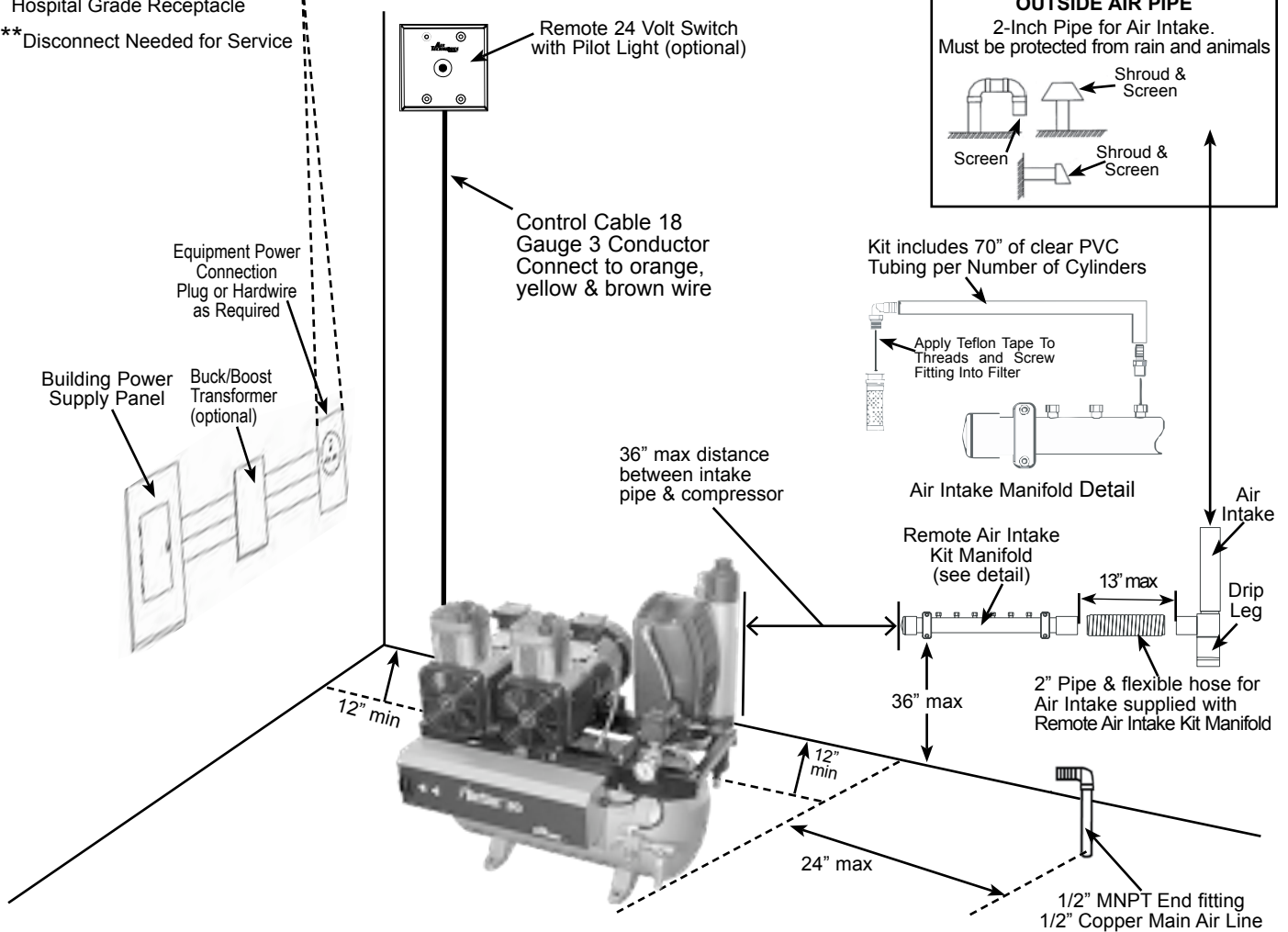

Figure 2. Overall Site Requirements

## INSTALLATION INFORMATION

**AIRSTARs** are installed by authorized Air Techniques dealer service technicians. Please review these installation guidelines to make sure that your **AIRSTAR** will work to capacity for your office. (See Site Requirements, pages 10 and 11)

- Your **AIRSTAR** should be installed in a well ventilated area, with at least 12 inch clearance on each side for service access and to prevent overheating during high demand periods. If other equipment is located in the vicinity, the ambient temperature of the area must not exceed 105°F.
- The installation site should be clean and dry to prevent the air intake filters from clogging. If there is a concern about the quality of air where the **AIRSTAR** is placed, we recommend an optional Remote Air Intake (See Optional Accessories, page 15) which allows the compressor to intake clean air from a remote location.
- Air distribution piping for all models should be 1/2", type "L" or type "K" copper.
- The minimum voltage for an AS10 or AS21 is 105 Volts. The minimum voltage required for an AS22, AS30, AS50 or AS70 is 200 Volts. Install a boost transformer if the service is below these ratings.

**Note:** If voltage is higher than 125V/250V, install a bucking transformer.

### ■ AIR SYSTEM PLUMBING CONNECTION:

The Tank Outlet Assembly (See Figure 1, View A), (the storage tank outlet for the dry air) is connected to the operatory air system via a 1/2" F.N.P.T. shut-off valve and 4 foot length of pressure hose (supplied).

### ■ ELECTRICAL CONNECTION:

- If your **AIRSTAR** comes with a line cord, plug it into a hospital grade electrical outlet.
- If your **AIRSTAR** comes with an electrical connections box, it must be wired directly in accordance with local electrical codes. (See Figure 3 below.)

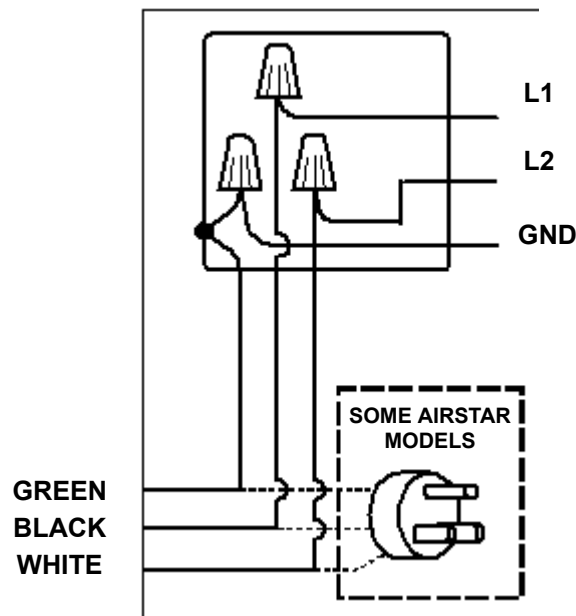

**Figure 3. Electrical Connection Box**

## POST INSTALLATION CHECK

### *Make Sure Everything Is Running Properly*

After your AIRSTAR has been installed and before it is put into operation, be sure to follow the check-out procedure detailed below:

- Check that Intake Filter(s) are fully seated into the compressor head(s) and that the Tank Outlet Valve is closed.
- Turn on the electricity. Check the incoming line voltage. It should be at least 105 Volts for the AS10 and AS21; and 200 Volts for the AS22, AS30, AS50 and AS70. This voltage should remain at or above these levels while the AIRSTAR is running. If not, install the appropriate boost transformer and check that the correct main circuit breaker and wire size are being used.
- Check pump-up and recovery times as detailed below and compare to the times in the table.
  - Turn on the AIRSTAR's power and determine the pump-up time from 0-115 PSI. See the table below.
  - Drain the storage tank to 80 PSI and determine the recovery time from 85 to 115 PSI. See the table below.

<b>Model</b>	<b>Number of Heads</b>	<b>Pump-up Time</b> 85-115 PSI Maximum	<b>Recovery Time</b> 85-115 PSI Maximum
AS21	1	3 minutes, 10 seconds	47 seconds
AS22	1	3 minutes, 10 seconds	47 seconds
AS30	2	3 minutes, 10 seconds	47 seconds
AS50	2	2 minutes, 50 seconds	42 seconds

If the recovery time differ as listed above, call authorized dealer for service.

# TROUBLESHOOTING

Problem	Possible Cause	Possible Solutions
1. Motor does not start.	<ul style="list-style-type: none"> <li>a. No electric power.</li> <li>b. Power not connected.</li> <li>c. Defective circuit breaker.</li> </ul>	<ul style="list-style-type: none"> <li>a. Check circuit breaker at main power panel.</li> <li>b. Check 24 Volt remote connections.</li> <li>c. Circuit breaker needs to be replaced. Call your authorized Air Techniques dealer for service.</li> </ul>
2. Motor tries to start, circuit breaker trips off. (* see bottom of page 10)	<ul style="list-style-type: none"> <li>a. Voltage too low. If each compressor head runs separately, but will not run together, the voltage is too low.</li> <li>b. Power supply cable too small.</li> <li>c. Loose electrical connection.</li> </ul>	<ul style="list-style-type: none"> <li>a. AS10 and AS21 require a minimum of 105 Volts. AS22, AS30, AS50 and AS70 require a minimum of 200 Volts. If the voltage is below the required minimum, a boost transformer must be installed. Call your authorized dealer.</li> <li>b. See SITE REQUIREMENTS Table.</li> <li>c. Call your authorized dealer for service.</li> </ul>
3. Unusual noise.	<ul style="list-style-type: none"> <li>a. Intake filter(s) not seated correctly.</li> <li>b. Intake filter(s) clogged or dirty.</li> <li>c. Motor noise.</li> <li>d. Air leaks</li> <li>e. Check cooling fans</li> </ul>	<ul style="list-style-type: none"> <li>a. Remove filter(s). Replace if clogged or dirty. When installing, make sure filter chamber is clean and rubber flange on top of filter is pushed all the way down into the metal cylinder</li> <li>b. Replace filter(s). ( PN 89831)</li> <li>c. Call your authorized dealer for service.</li> <li>d. Call your authorized dealer for service.</li> <li>e. If fan is loose or broken, call your authorized dealer for service.</li> </ul>
4. Compressor cycles but no pressure buildup to 115 psi.	<ul style="list-style-type: none"> <li>a. Motor noise.</li> <li>b. Leak in compressor.</li> </ul>	<ul style="list-style-type: none"> <li>a. Replace filter(s). ( PN 89831)</li> <li>b. Close the storage tank outlet valve. Check all fittings for leaks. If a leak is found, call your authorized dealer for service.</li> </ul>
	<ul style="list-style-type: none"> <li>c. Pressure switch needs to be adjusted.</li> </ul>	<ul style="list-style-type: none"> <li>c. Disconnect the main power supply. Drain the storage tank slowly until a "click" is heard. Storage tank pressure should read 85 PSI on the pressure gauge. Close the tank outlet valve, turn on the power switch and verify the pump-up time for your model AirStar. Call your authorized dealer if the pump-up time is incorrect. (See Post Installation Check for pump-up times.)</li> </ul>

Problem	Possible Cause	Possible Solutions
<p>5. Compressor cycles when there is no air demand from the operator.</p>	<p>a. Leak in the compressor.</p> <p>b. Leak in the office air system.</p>	<p>a. Disconnect the main power supply. Drain the storage tank slowly until a “click” is heard. Storage tank pressure should read 87 PSI on the pressure gauge. Close the tank outlet valve, turn on the power switch and verify the pump-up time for your model AirStar. Call your authorized Air Techniques dealer if the pump-up time is incorrect. (See Post Installation Check for pump-up times.)</p> <p>b. Look at the moisture monitor (see KEY PARTS to locate).  <b><i>If it is blue, perform the following:</i></b></p> <ol style="list-style-type: none"> <li>1. With the AirStar’s power switch ON, drain the storage tank to 85 PSI to start the compression cycle.</li> <li>2. When the cycle shuts off at 115 PSI, close the storage tank outlet valve.</li> <li>3. Wait 5 minutes and open the storage tank outlet valve.</li> <li>4. If the pressure drops, the air leak is in the office air system or delivery units and not in the AirStar. Call your dealer or plumber for service.</li> </ol> <p><b><i>If it is pink, see #6 below</i></b></p>
<p>6. Moisture monitor is not blue (pink or white).</p>	<p>a. Leak in the office air system.</p> <p>b. Compressor keeps cycling.</p>	<p>a. If the moisture monitor is pink, there is too much moisture in the system. Call your authorized Air Techniques dealer for service.</p> <p>b. Check the SIZING GUIDE. There may be excessive air demands placed on the AirStar. A larger capacity model may be required.</p>

**\*DIAGNOSTIC PROCEDURE FOR DEFECTIVE COMPRESSOR HEAD(S)**

1. Put power switches in the OFF position.
2. Reset the circuit breaker if it was previously tripped.
3. Test heads by turning ONE on at a time. If the motor fails to start, or the circuit breaker trips, the problem may be in that compressor head. Leave the power switch for the effective head in the OFF position. Call your Authorized Air Techniques dealer for service.

**NOTE:** One head may be run TEMPORARILY while waiting for service.

4. If all heads run independently, but will not run together, check the line voltage. If the voltage is within the min./max. voltage required in PRODUCT SPECIFICATIONS, call your Authorized Air Techniques dealer for service.

## PRODUCT SPECIFICATIONS

---

Requirement \ AirStar Model	AirStar 21	AirStar 22	AirStar 30	AirStar 50	
<b>Horsepower/Kilowatts</b>	1.5/1.1	1.5/1.1	1.5/1.1	3.0/2.2	
<b>Voltage Rating</b>	115	208/230	208/230	208/230	
<b>Frequency (Hz)</b>	60	60	60	60	
<b>Voltage Min./Max. (VAC)</b>	105/125	200/250	200/250	200/250	
<b>CFM</b> (Cubic Ft./Min) @ 80 psi	5.0	5.0	5.0	10.0	
<b>Pump-up Time</b> 85-115 PSI	3 minutes, 10 seconds	3 minutes, 10 seconds	3 minutes, 10 seconds	2 minutes, 50 seconds	
<b>Recovery Time</b> 85-115 PSI	47	47	47	42	
<b>Tank Size</b> (cu. ft.) (US Gal.)	1.6 12	1.6 12	1.6 12	2.7 20	
<b>Shipping Weight</b> (Approximate lbs)	210	210	255	320	
<b>Dimensions (inches)</b>	H	30.5	30.5	30.5	33.5
	W	29.0	29.0	29.0	35.5
	D	19.0	19.0	19.0	20.0

## REPLACEMENT PARTS

---

Description	Part No.
Intake Filter (factory installed 10 micron)	89831
5 Micron Replacement Filter Element	86193
Filter Retainer and Element Baffle	86195
Replacement Filter Bowl	86197

- Change the Intake Filters, PN 89831 once a year, or more often in dusty environments. See Figure 4.
- To comply with NFPA 99C, a 5-micron Filter is installed on all AIRSTAR models.
- Periodically inspect the Moisture Monitor. A “blue” Moisture Monitor indicates that the air in the storage tank is dry. A “pink” Moisture Monitor indicates a high level of humidity in the storage tank. To correct this situation, see TROUBLESHOOTING page 12. See Figure 5.
- The only consumable parts on the AIRSTAR are the intake filter and the 5-micron exhaust filter element. See Figure 6. When replacing either filter, dispose of the removed filter in accordance with local codes.

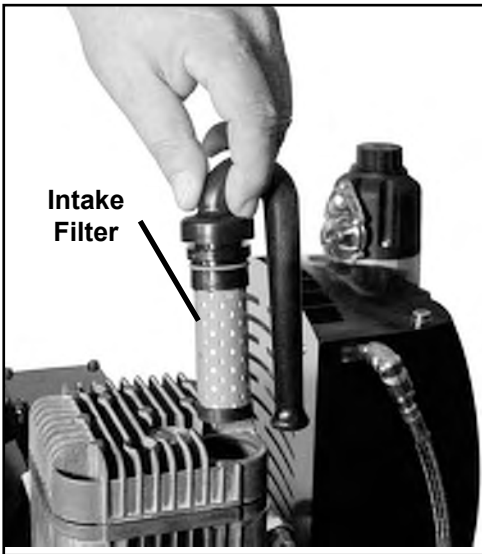

**Figure 4. Intake Filter Location**



**Figure 5. Moisture Monitor Location**



**Figure 6. 5 Micron Filter Location**

**OPTIONAL ACCESSORIES**

Description	Model	Part Number
REMOTE AIR INTAKE KIT	AirStar 21, 22, 30 AirStar 50	85492 85493
REMOTE CONTROL PANEL w/24 V switches	For all AirStars	
1-Switch Plate Kit		53111
2-Switch Plate Kit		53251
3-Switch Plate Kit		53250
4-Switch Plate Kit		53133

Air Techniques is a leading manufacturer of dental products including air and vacuum systems, film processors, digital imaging systems and intra-oral digital video systems. We have been manufacturing quality products for dental professionals since 1962.

Air Techniques' products are only distributed through authorized dealers.

- A/T 2000<sup>®</sup> XR
- Accent<sup>™</sup>
- AirStar<sup>®</sup>
- CleanStream<sup>™</sup>
- Guardian<sup>™</sup>
- Peri-Pro<sup>®</sup>
- Polaris<sup>™</sup>
- ScanX<sup>®</sup>
- Sensa<sup>™</sup>
- Spectra<sup>™</sup>
- STS<sup>™</sup>
- VacStar<sup>™</sup>
- Visix<sup>™</sup>



1295 Walt Whitman Road, Melville, NY 11747-3062  
1-800-AIR-TECH (1-800-247-8324) • [www.airtechniques.com](http://www.airtechniques.com)